



Technical Data

# TEMPERED GLASS MIRROR WITH STAINLESS STEEL CHANNEL FRAME

## B-1658 1639

### SCREW LOCKING DESIGN

(Rear View)

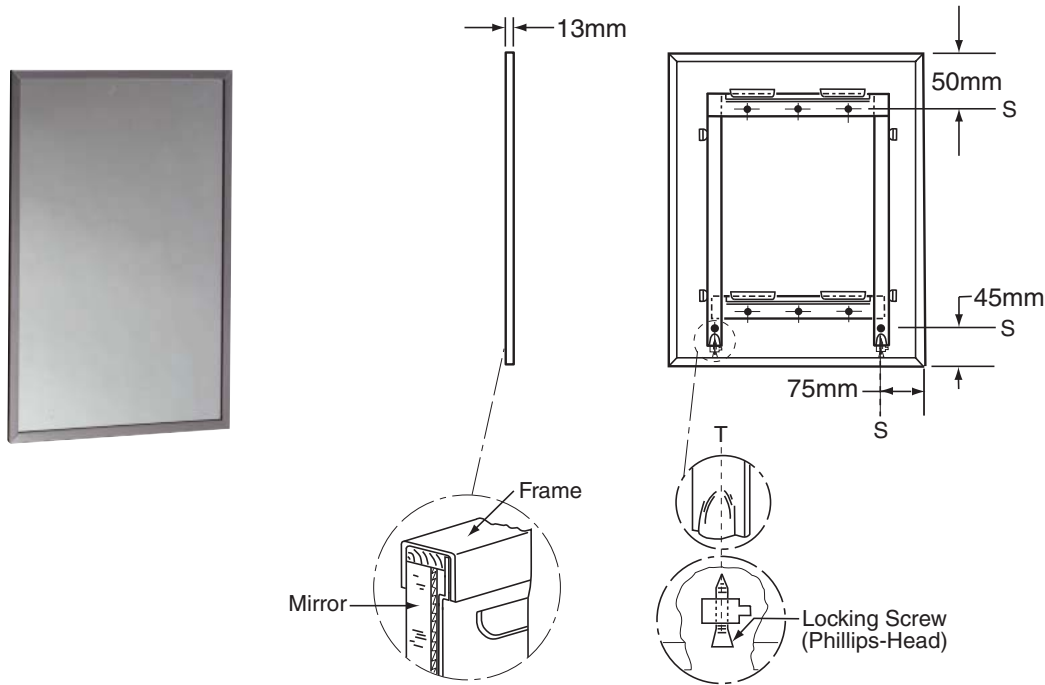

#### Designer's Notes:

1. Special-order only.
2. All Bobrick framed mirrors are manufactured to overall width and height dimensions. Mirror will be furnished 40.6 x 99cm outside-of-frame to outside-of-frame.
3. Bobrick framed mirrors are manufactured to a tolerance  $\pm 3.2$ mm.
4. For sufficient space to lift mirror onto wall hanger, provide 75mm minimum clearance above center line of mounting screw holes.
5. Provide 25mm minimum clearance at bottom of mirror for engaging locking screws and 25mm clearance on each side.

#### MATERIALS:

**Frame** — Type 430 stainless steel, 13 x 13 x 13mm channel with bright polished finish. One-piece frame with 90° mitered corners. Galvanized steel back with formed edges for additional strength has integral horizontal hanging brackets located near top. Concealed Phillips-head locking screws securely fasten mirror to wall hanger.

**Mirror** — (B-1658 Series) No. 1 quality, 6mm tempered select float glass: selected for silvering and electrolytically copper-plated by the galvanic process.

**Note:** These reflective surfaces resist breakage and provide a measure of safety from broken glass, but differ in color and reflective quality from standard glass mirrors.

Corners are protected by friction-absorbing filler strips. Backs of all glass mirrors are protected by full-size, shock-absorbing, water-resistant, nonabrasive, 5mm thick polyethylene padding.

**Concealed Wall Hanger(s)** — 20-gauge (0.9mm) galvanized steel. Incorporates lower support member, forming rigid rectangle, which engages lower backplate louvers to keep bottom of mirror against wall.

continued . . .

## INSTALLATION:

Mount wall hanger on wall with screws (not furnished) at points indicated by an *S*. For plaster or drywall construction, provide concealed backing to comply with local building codes, then secure wall hanger with screws (not furnished). For other wall surfaces, provide fiber plugs or expansion shields for use with screws (not furnished), or provide 3mm toggle bolts or expansion bolts. Hang mirror on wall hanger. Lock mirror to wall hanger by tightening Phillips-head locking screws that are concealed in bottom of frame at points indicated by a *T*.

**Screw Locking Design** — Lock mirror to wall hanger by tightening Phillips-head locking screws that are concealed in the bottom of frame at points indicated by a *T*. Mirror may be unlocked from wall hanger by loosening locking screws and lifting mirror off of concealed wall hanger.

### SCREW LOCKING DESIGN (Front View)

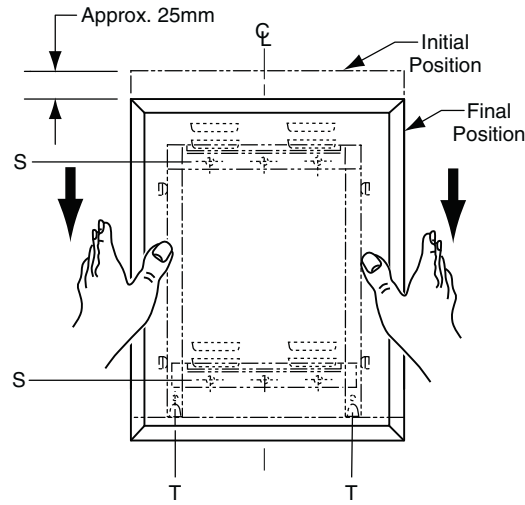

## SPECIFICATION:

Mirror shall have a one-piece type 430 stainless steel channel frame, 13 x 13 x 13mm, with 90° mitered corners; all exposed surfaces shall have bright polished finish. Mirror shall be tempered glass. Corners shall be protected by friction-absorbing filler strips. Backs of all glass mirrors shall be protected by full-size, shock-absorbing, water-resistant, nonabrasive, 5mm thick polyethylene padding. Galvanized steel back shall have integral horizontal hanging brackets located near top for mounting on concealed wall hanger. Mirror shall be secured to wall hanger with concealed Phillips-head locking screws located in bottom of frame.



RYNAT INDUSTRIES AUSTRALIA PTY LTD | [www.rynat.com](http://www.rynat.com) | Email: [sales@rynat.com](mailto:sales@rynat.com) |  
| Aust Wide: 1300 558 518 | Tel: +61 8 6254 6555 | 20 Murray Rd South Welshpool WA |