

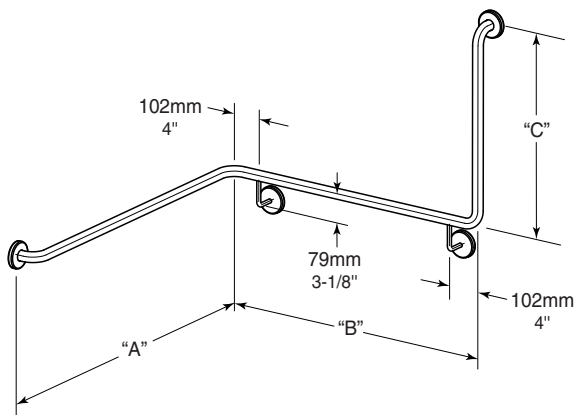

# Technical Data

32mm Diameter Stainless Steel 90 Degree  
Wrap Around Grab Bars with Snap Flange  
B819491 - B819492 | To Suit AS1428.1 - 2009

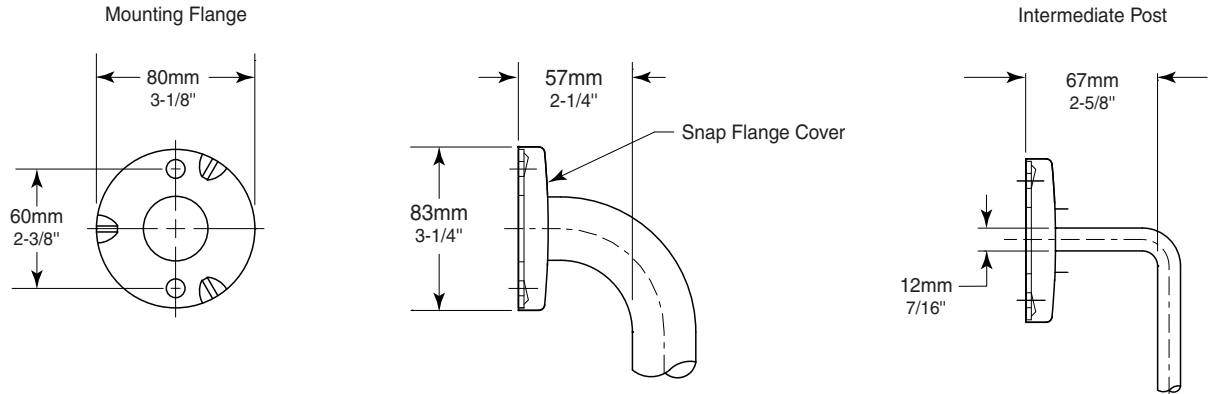

**Left Hand Wraparound**

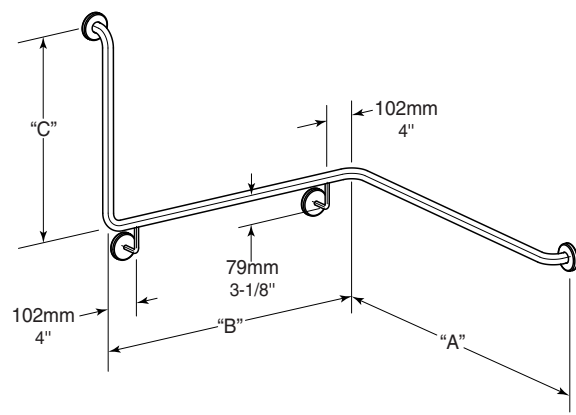

**Right Hand Wraparound**

Model	"A"	"B"	"C"
<b>819492</b>	1000mm (39-3/8")	975mm (38-3/8")	600mm (23-5/8")

Model	"A"	"B"	"C"
<b>819491</b>	1000mm (39-3/8")	975mm (38-3/8")	600mm (23-5/8")

The illustrations and descriptions herein are applicable to production as of the date of this Technical Data Sheet. The manufacturer reserves the right to, and does from time to time, make changes and improvements in designs and dimensions.

Revised 3/09



## Technical Data

32mm Diameter Stainless Steel 90 Degree  
Wrap Around Grab Bars with Snap Flange  
B819491 - B819492 | To Suit AS1428.1 - 2009

### MATERIALS:

**Grab Bar** — 18-8 S, type-304, 1.2mm (18-gauge) stainless steel tubing with satin finish. 32mm (1-1/4") outside diameter. Ends are heliarc welded to concealed mounting flanges. Clearance between the grab bar and wall is 57mm (2-1/4").

**Concealed Mounting Flanges** — 18-8 S, type-304, 3mm (1/8") thick, stainless steel plate; end flanges 80mm (3-1/8") diameter with two holes for attachment to wall.

**Snap Flange Covers** — 18-8 S, type-304, 0.8mm (22-gauge) drawn stainless steel with satin finish. 83mm (3-1/4") diameter x 14mm (9/16") deep. Each cover snaps over mounting flange to conceal mounting screws.

### STRENGTH:

Grab bar configurations can support loads in excess of 113kg (1108N) if properly installed, complying with accessibility guidelines (including AS 1428.1-2001) for structural strength.

**Warning:** *Grab bars are no stronger than the anchors or walls to which they are attached and, therefore, must be firmly secured in order to support the loads for which they are intended.*

### INSTALLATION:

Provide concealed anchor device or backing as specified or required in accordance with local building codes before wall is finished. Fasten concealed mounting flanges to anchor device or backing with two screws in each flange. Snap flange covers over each mounting flange to conceal mounting screws. Concealed anchor devices and mounting screws are not included with Bobrick grab bars and must be specified as an accessory.

#### Important Notes:

1. **Concealed Anchor Device** — Bobrick grab bar anchor device includes stainless steel machine screws to be used for attaching grab bars to anchors. **one Bobrick concealed anchor device is required for each flange.**

Concealed Anchor No.	Type Of Installation
2573	Anchor for solid wall construction; 1 anchor required for each flange.

2. **Mounting Kits** — Bobrick has a selection of mounting screws and fasteners available for different types of installations; **one Bobrick mounting kit is required for each flange.**

Mounting Kit No.	Description
252-30	Consists of (3) M6.3 x 64mm (#14 x 2½") type-304 stainless steel, Phillips round-head, sheet-metal screws.
2521-30	Consists of (3) M6.3-1 x 89mm (1/4"-20 x 3½") type-304 stainless steel, Phillips round-head, machine screws with plated-steel toggle nuts.
2522-30	Consists of (3) M6.3-1 x 51mm (1/4"-20 x 2") type-304 stainless steel, Phillips round-head, machine screws with metal expansion shields.

3. **Grab Bar Fastener** — Bobrick has a grab bar fastening system that secures all Bobrick grab bar series; **one Bobrick fastener is required for each flange.** Install grab bar without backing in wall requires minimum 16mm (5/8") thick painted or tiled drywall.

WingIt™ Fastener No.	Description
251-4	Consists of (3) 10-32 x 5/16" round-head, Phillips 18/8 stainless steel screws. (1) WingIt grab bar fastener.

### SPECIFICATION:

Grab bar shall be type-304 stainless steel with satin finish. Grab bar shall have 1.2mm (18-gauge) wall thickness and 32mm (1-1/4") outside diameter. Clearance between the grab bar and wall shall be 57mm (2-1/4"). Concealed mounting flanges shall be 3mm (1/8") thick stainless steel plate, 80mm (3-1/8") diameter, and equipped with two screw holes for attachment to wall. Flange covers shall be 0.8mm (22-gauge) stainless steel, 83mm (3-1/4") diameter, and shall snap over mounting flanges to conceal mounting screws and/or WingIt fasteners. Ends of grab bar shall pass through concealed mounting flanges and be heliarc welded to form one structural unit. Grab bar shall comply with barrier-free accessibility guidelines (including AS 1428.1-2001) for structural strength. Manufacturer's service and parts manual shall be provided to the building owner/manager upon request.

The illustrations and descriptions herein are applicable to production as of the date of this Technical Data Sheet. The manufacturer reserves the right to, and does from time to time, make changes and improvements in designs and dimensions.

Revised 3/09