

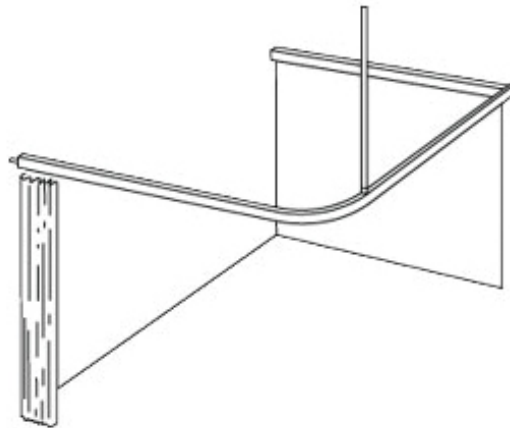

## Technical Data

Curtain Track System  
(To Suit AS1428.1 - 2009)  
AL16C



**Model:** AL16C (Suits Australian Standards AS 1428.1-2009)

**Size:** 1600mm x 1200mm wide

**Includes:** Rail, Hooks and White Curtain

- Strong Durable Aluminium Anodised Shower Track
- 1000mm Ceiling Supports (cut to length required)
- Concealed Fixings
- Hooks included
- Curtains are Flame Resistant (AS2722.2-1985)
- Mould Resistant and Machine Washable

Curtain lengths available:

1800mm wide x 1800mm long

1800mm wide x 2100mm long

2400mm wide x 1800mm long

2400mm wide x 2100mm long

Vinyl Shower Curtains shall be Model \_\_\_\_\_ (insert model number) of Bobrick Washroom Equipment, Inc., Clifton Park, New York; Jackson, Tennessee; Los Angeles, California; Bobrick Washroom Equipment Company, Scarborough, Ontario; Bobrick Washroom Equipment Pty. Ltd., Australia; and Bobrick Washroom Equipment Limited, United Kingdom.

The illustrations and descriptions herein are applicable to production as of the date of this Technical Data Sheet. The manufacturer reserves the right to, and does from time to time, make changes and improvements in designs and dimensions.

Revised 8/04/15