

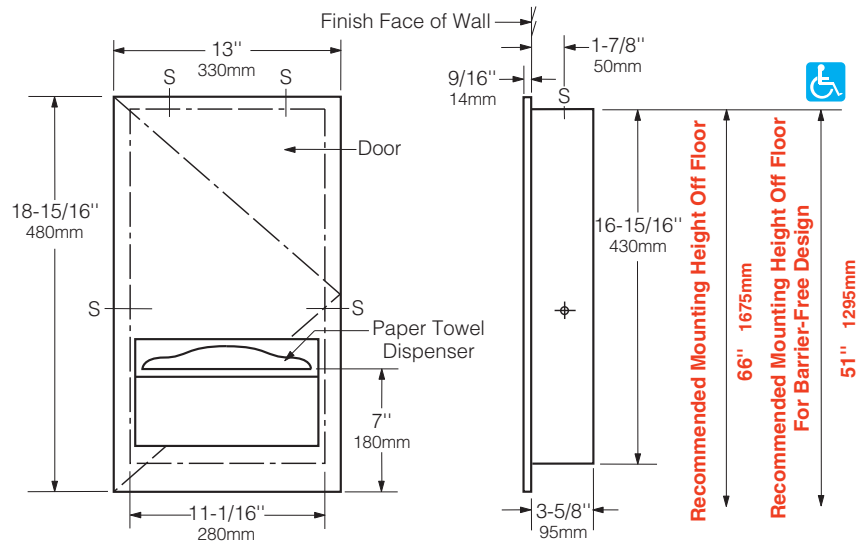

Technical Data

Recessed Paper Towel Dispenser
B35903

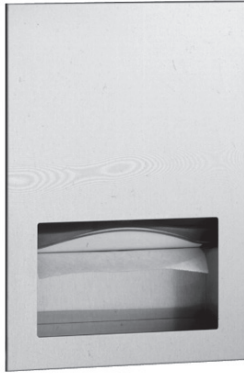

Rough Wall Opening
 11-1/2" (290mm) wide
 17-1/4" (440mm) high
 3-3/4" (95mm) minimum
 recessed depth

MATERIALS:

Cabinet — 18-8 S, type-304, heavy-gauge stainless steel. All-welded construction. Exposed surfaces have satin finish.

Door — 18-8 S, type-304, 18-gauge (1.2mm) stainless steel. 9/16" (14mm) 90° return edges for maximum rigidity. Secured to cabinet with a concealed, full-length stainless steel piano-hinge. Equipped with a stainless steel cable door-swing limiter and friction catch.

Paper Towel Dispenser — 18-8 S, type-304, 22-gauge (0.8mm) stainless steel. Capacity: 300 C-fold or 400 multifold paper towels.

OPERATION:

Paper towel dispenser accommodates C-fold and multifold paper towels without adjustment or use of adapters. Door-swing limiter prevent damage to washroom accessories and walls.

INSTALLATION:

Provide framed rough wall opening 11-1/2" wide x 17-1/4" high (290 x 440mm). Minimum recessed depth required from finish face of wall is 3-3/4" (95mm). Allow clearance for construction features that may protrude into rough wall opening from opposite wall. Coordinate with mechanical engineer to avoid pipes, vents, and conduits in wall. Mount cabinet with shims between framing and cabinet at all points indicated by an S, then secure unit with sheet-metal screws furnished by manufacturer.

SPECIFICATION:

Recessed paper towel dispenser shall be type-304 stainless steel with all-welded construction; exposed surfaces shall have satin finish. Door shall be 18 gauge (1.2mm); have 9/16" (14mm) 90° return edges; be secured to cabinet with a concealed, full-length stainless steel piano-hinge; and equipped with a stainless steel cable door-swing limiter and friction catch. Paper towel dispenser shall be able to dispense 300 C-fold or 400 multifold paper towels without adjustment or adapters. Manufacturer's service and parts manual shall be provided to the building owner/manager upon request.

Recessed Paper Towel Dispenser shall be Model B-35903 of Bobrick Washroom Equipment, Inc., Clifton Park, New York; Jackson, Tennessee; Los Angeles, California; Bobrick Washroom Equipment Company, Scarborough, Ontario; Bobrick Washroom Equipment Pty. Ltd., Australia; and Bobrick Washroom Equipment Limited, United Kingdom.

The illustrations and descriptions herein are applicable to production as of the date of this Technical Data Sheet. The manufacturer reserves the right to, and does from time to time, make changes and improvements in designs and dimensions.

Revised 5/06