

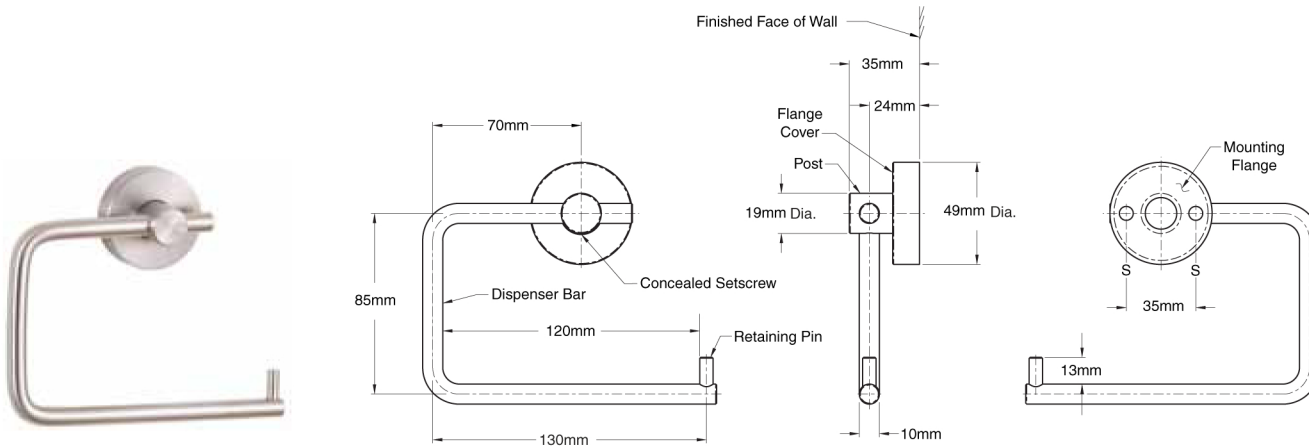

## Technical Data

Toilet Tissue Dispenser  
B543



### MATERIAL:

**Post** — 18-8 S, type-304, 19mm (3/4") diameter, solid stainless steel rod with satin-finish. Post and Concealed Mounting Threaded Flange are machined as one piece.

**Dispenser Bar** — 18-8 S, type-304, 9.5mm (3/8") diameter, solid stainless steel rod with satin-finish. Secured to Post with a concealed set screw allowing for right or left handed assembly.

**Retaining Pin** — 18-8 S, type-304, 6.4mm (1/4") diameter, solid stainless steel rod with satin-finish press fit and secured into Dispenser Bar.

**Concealed Mounting Threaded Flange** — 18-8 S, type-304, 5.6mm (7/32") thick, stainless steel plate with thread on outside edge for fastening cover. 46mm (1-13/16") outside diameter with two holes for attachment to wall.

**Threaded Flange Cover** — 18-8 S, type-304, 1.4mm (17-gauge), machined stainless steel with satin-finish. 49mm (1-15/16") diameter 13mm (1/2") deep. Cover fastens over mounting flange to conceal mounting screws.

### INSTALLATION:

For plaster or dry wall construction, provide concealed backing to comply with local building codes, then secure unit with sheet-metal screws (not furnished). For other wall surfaces, provide fiber plugs or expansion shields for use with sheet-metal screws (not furnished), or provide 3mm (1/8") toggle bolts or expansion bolts.

For partitions with particle-board or other solid core, secure with sheet-metal screws (not furnished), or provide through-bolts, nuts, and washers. For hollow-core metal partitions, provide solid backing into which the sheet-metal screws (not furnished) can be secured.

### SPECIFICATION:

Toilet Tissue Dispenser shall be type-304 stainless steel with satin finish. Toilet Tissue Dispenser shall have 19mm (3/4") diameter Post. Dispenser bar shall be 9.5mm (3/8") diameter, secured to Post with a concealed set screw allowing for right or left handed assembly. Retaining pin shall be 6.4mm (1/4") diameter and pressed into Dispenser bar. Concealed mounting flange shall be 5.6mm (7/32") thick stainless steel plate, 46mm (1-13/16") outside diameter and equipped with two screw holes for attachment and thread on outside edge to fasten cover. Threaded flange cover shall be 1.4mm (17-gauge) stainless steel, 49mm (1-15/16") diameter and shall fasten over mounting flange to conceal mounting screws. Post and mounting flange are to be machined as one piece.