

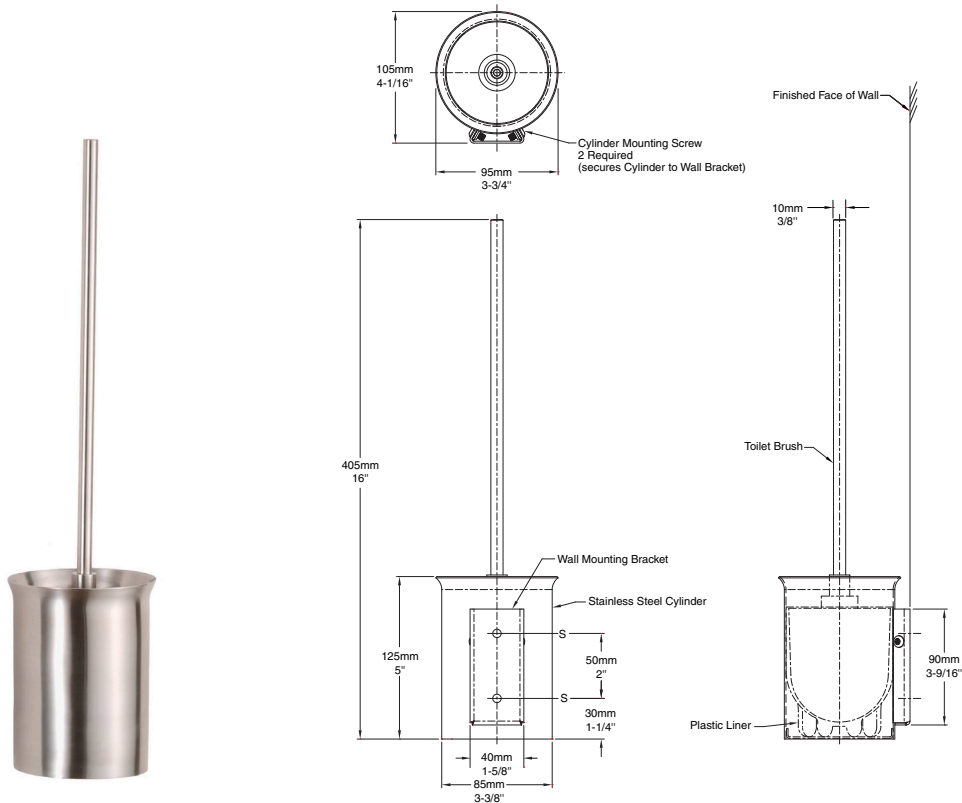

Technical Data

Toilet Brush Holder
B544



MATERIAL:

Toilet Brush — 18-8 S, type-304, 9.5mm (3/8") diameter, stainless steel handle with satin-finish, threaded into toilet brush head.

Plastic Liner — Leak-proof molded polyethylene. Supports Toilet Brush to maintain it in a vertical position. Removable for cleaning.

Cylinder — 18-8 S, type-304, 1.2mm (18-gauge) stainless steel with satin-finish, seamless construction.

Wall Bracket — 18-8 S, type-304, 1.5mm (16-gauge) stainless steel with satin-finish. Equipped with screws to secure cylinder.

INSTALLATION:

For plaster or dry wall construction, provide concealed backing to comply with local building codes, then secure unit with sheet-metal screws (not furnished). For other wall surfaces, provide fiber plugs or expansion shields for use with sheet-metal screws (not furnished), or provide 3mm (1/8") toggle bolts or expansion bolts.

For partitions with particle-board or other solid core, secure with sheet-metal screws (not furnished), or provide through-bolts, nuts, and washers. For hollow-core metal partitions, provide solid backing into which the sheet-metal screws (not furnished) can be secured.

SPECIFICATION:

Toilet Brush Holder shall be type-304 stainless steel with satin finish. Toilet Brush Holder shall have 9.5mm (3/8") diameter toilet brush handle threaded into toilet brush. Unit shall be equipped with a removable, leak proof plastic liner to hold toilet brush in vertical position. Cylinder shall be 1.2mm (18-gauge), seamless construction. Cylinder shall be secured to the wall with screws secured into wall plate.

Toilet Brush Holder shall be Model B-544 of Bobrick Washroom Equipment, Inc., Clifton Park, New York; Jackson, Tennessee; Los Angeles, California; Bobrick Washroom Equipment Company, Scarborough, Ontario; Bobrick Washroom Equipment Pty. Ltd., Australia; and Bobrick Washroom Equipment Limited, United Kingdom.

The illustrations and descriptions herein are applicable to production as of the date of this Technical Data Sheet. The manufacturer reserves the right to, and does from time to time, make changes and improvements in designs and dimensions.

Revised 3/09