

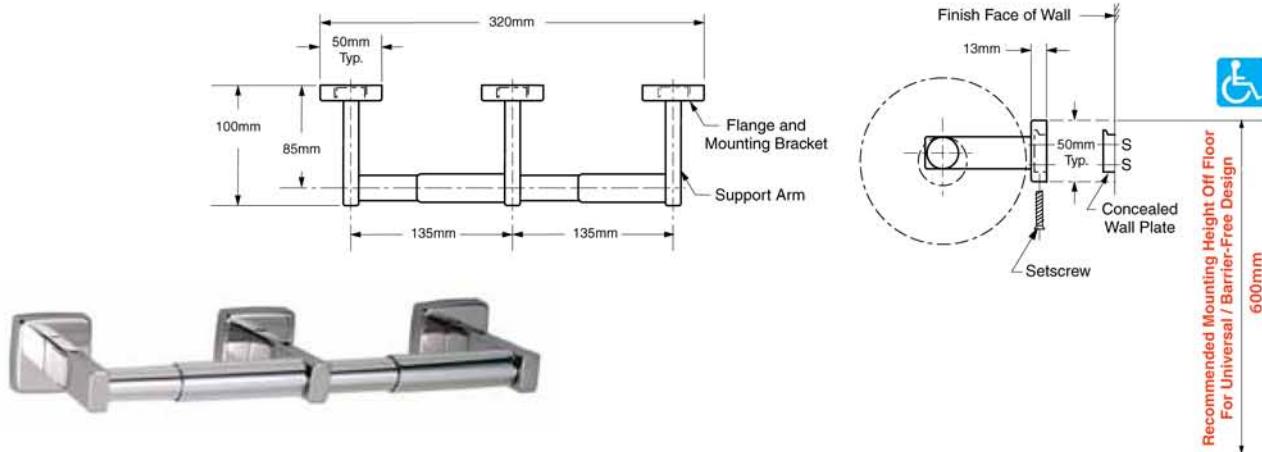

# Technical Data

Double Roll Toilet Tissue Dispenser  
B686-B687

- Specify Model Required:**
- Model B-686 Bright polished stainless steel
  - Model B-6867 Satin-finish stainless steel



## MATERIAL:

**Flanges and Support Arms (3)** — 18-8 S, type-304, 22-gauge (0.8mm) stainless steel. Concealed, 16-gauge (1.6mm) stainless steel mounting bracket is welded inside each flange. Secured to wall plate with setscrew.

**Concealed Wall Plates (3)** — 18-8 S, type-304, 16-gauge (1.6mm) stainless steel.

**Spindles (2)** — Chrome-plated plastic. Equipped with heavy-duty internal springs.

*Designer's Note:* Theft-resistant spindles, which are removable only with special key provided, are available as optional accessories. To specify, add suffix .60 to model number. Example B-686.60.

## INSTALLATION:

To remove concealed wall plates from back of flanges and mounting brackets, loosen setscrews. Mount each wall plate with prongs at top; secure with sheet-metal screws furnished by manufacturer at points indicated by an S. Engage mounting brackets onto prongs of wall plate, then secure into position by tightening setscrews at bottom of flanges.

**Note:** Center-to-center of concealed wall plates must be within 1/16" (1.6mm) of dimension shown.

For partitions with particle-board or other solid core: Secure with sheet-metal screws furnished by manufacturer or provide through-bolts, nuts, and washers.

For hollow-core metal partitions: Provide solid backing into which the furnished sheet-metal screws can be secured. If two units are installed back-to-back, then provide threaded sleeves and machine screws for the full thickness of partition.

For masonry walls: Provide fiber plugs or expansion shields for use with sheet-metal screws furnished by manufacturer, or provide 1/8" (3mm) toggle bolts or expansion bolts.

For plaster or dry wall construction: Provide concealed backing to comply with local building codes, then secure the unit with sheet-metal screws furnished.

## SPECIFICATION:

Double-roll toilet tissue dispenser shall be type-304 stainless steel with \_\_\_\_\_ (insert one: bright polished or satin) finish. Unit shall accommodate two standard-core toilet paper rolls up to 5-1/2" (140mm) diameter (1800 sheets). Flanges shall be equipped with concealed, 16-gauge (1.6mm) stainless steel mounting brackets that are secured to concealed stainless steel wall plates with stainless steel setscrews. \*Spindles shall be equipped with a heavy-duty internal spring. Manufacturer's service and parts manual shall be provided to the building owner/manager upon request.

*\*To specify theft-resistant spindles as an optional accessory, add to specification:* Theft-resistant spindles shall be removable only with special key provided.